

GASOLINE-ELECTRIC HYBRID BIKE

Martin Prudík

Doctoral Degree Programme (2), FEEC BUT

E-mail: xprudi00@stud.feec.vutbr.cz

Supervised by: Pavel Vorel

E-mail: vorel@feec.vutbr.cz

Abstract: Discussion about a gasoline-electric hybrid drivetrain for a bike is performed on the beginning of this article. A design of a DC/DC converter needed for the traction purpose is introduced in the remaining part of the article. The gasoline-electric hybrid bike is designed as a functional presentation utility where features of hybrid drivetrain can be easily observed.

Keywords: DC/DC converter, series-hybrid drive.

1. INTRODUCTION

Hybrid drive which is based on gasoline-electric connection is currently very popular in the automotive industry. High efficiency of the drive which is associated with lower fuel consumption and lower emission level, is a major advantage. An idea of implementing a hybrid drive to a bike construction was created to approach a principle presentation of the drivetrain to students. The hybrid drivetrain is an extension of an electric bike that is described in [1]. The article was focused on the design of the DC drive for an electric bike with a brushed disk DC motor. The converter is characterized by atypical topology of power part and uncommon layout which is a result of effort to dimension minimization.

2. CONCEPT OF DRIVETRAIN

Series-hybrid drive is suitable for small vehicles as a bicycle [9]. Series-hybrid vehicles are driven only by electric traction. Unlike combustion engines, electric motors are efficient with extraordinarily high power-to-weight ratios providing adequate torque over a wide speed range as well as the vehicle do not require a shifting transmission between the engine and wheels. However between the electric motor and wheel is suitable to have an one-speed gearbox. In a series-hybrid drive, the combustion engine drives an electric generator instead of directly driving the wheels (see fig. 1). The engine operates in optimal speed range therefore the engine works with high efficiency. It means that the engine is smaller, has better fuel consumption and is environmentally friendly. The generator provides power for the driving electric motors or storage battery or ultracapacitor which serves as an energy buffer in case of larger or smaller motor performance than the generator output.

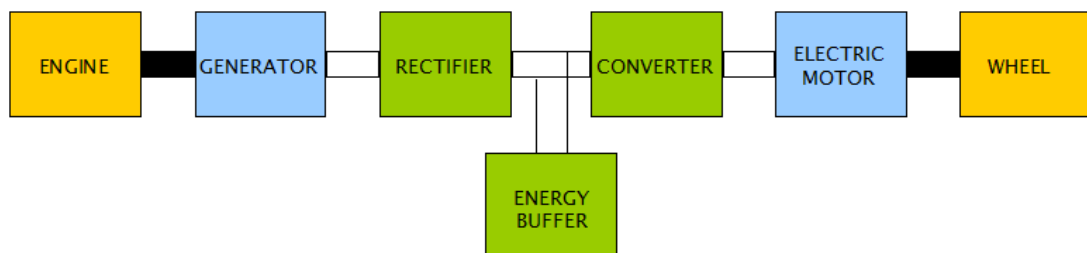

Figure 1 Structure of a series-hybrid vehicle

Design of hybrid drivetrain for bicycle is subordinate to the fact that an electric motor, electric generator and a combustion engine are assigned. All these devices are available for this project and design of a converter must be adapted to these facts. Brushed disk motor RN120-2NFB by Heinzman is used. This motor has huge torque and motor construction is suitable for woven into a bike wheel. Four-stroke single-cylinder combustion engine EH035 by Robin America (fig. 2) is used as a source of mechanical energy. The engine has nominal power 0.81kW and speed range from 4000 to 7500 rpm. The desired power can be simply managed by help of a servo which drives an accelerator throttle. Brushless motor AXI 5345/18 (fig. 2) serves as an electric generator. The generator has speed constant 171rpm/V which means that the output voltage moves from 22 to 44V.



Figure 2 Electric generator and combustion engine connection

2.1. CONCEPT OF CONVERTER

The motor RN120-2NFB has nominal voltage 24V, nominal power 250W and nominal current 13A. To achieve the huge torque of the motor a planetary gearbox in the body of the motor is implemented. Then nominal torque 24.6Nm and nominal speed 97rpm with nominal efficiency 78.9% is at the output of the gearbox. The bike speed at the nominal motor speed is 11km/h. With respect to the control and drive-ability the motor voltage should be set in a range of 0 to 70V. If the maximal voltage 70V on the motor is set then maximal speed of the motor is 269rpm i.e. maximal speed of bike is 36km/h. In this case the motor is overloaded by high voltage. A current control is implemented. The motor current is limited at the maximal current 28A - or less at high voltage for which it would threaten the destruction of brushes. The maximal motor power is 1010W at speed 22km/h. The power is limited to 507W at the maximal speed 34km/h which is better because of commutation problems and power losses. A higher noise of the bike is a disadvantage of this solution.

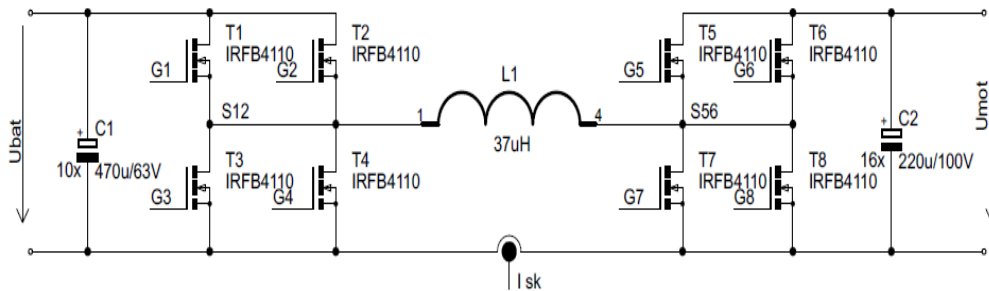

Figure 3 Topologies of power stage circuit [1]

Topology of power part can be seen in figure 3. Basically it is a cascade connection of step-down and step-up converter. When lower voltage than nominal one is required, the step-down converter (transistors T1 to T4) is switched by PWM rhythm. Upper transistors (T5, T6) at the second converter are permanently opened. When higher voltage than nominal one is required, the upper transistors at the step-down converter (T1, T2) are permanently opened, and the step-up converter (T4 to T8) is switched by PWM rhythm. Two parallel sorted MOS-FET transistors IRFB4110 [4] are used in each branch of converter and the efficiency of the converter is increased. Total losses of the transistors are 15W at 25kHz. Capacitors are used as a local energy accumulator. For smaller dimensions 10 capacitors with parameters 470uF/63V are used. Capacitors connected to the motor provide smooth motor voltage, due to large current 16 capacitors with parameters 220uF/100V are used. The choke (L1) represents a fundamental necessity for the function of the step-up converter. 2 parallel chokes are used with diameter 46mm and height 26mm. The resulting inductance is 37uH and current ripple is acceptable (6%).

3. CONTROL CIRCUITS

Digital control based on DSC was used. The main advantages of digital control are smaller dimensions, less components, simpler schema and especially adaptability of the control algorithm.

3.1. DSC

Digital signal controller MC56F8322 by Freescale is used to the control of the converter. This basic DSC is fully sufficient because it includes all needed peripherals (PWM, AD converter, GPIO, timers etc.) [3].

3.2. SENSING OF ELECTRICAL PARAMETERS

It is necessary to measure the battery voltage and motor voltage for needs of control. Both voltages are measured by classic resistance voltage dividers. Then the signal is brought into the ADC input of DSC.

Motor current has to be measured for needs of subordinate current loop that is implemented in DSC but for constructional reasons it is preferable to measure the current of the choke and to calculate the motor current in DSC. The current is measured by current transducer LTS 25- NP by LEM [5]. The transducer is based on the Hall effect, it has closed compensated loop, unipolar voltage supply, nominal current 25A, maximal current 80A and it has a voltage output which is connected to AD converter of DSC.

3.3. DRIVERS

The schema of the driver which is used for optimal switching of two parallel connected MOS-FET power transistors is shown in fig. 4. The circuit is composed with the optocoupler HCPL-0600 which serves as a galvanic separation of driver and control circuits. The integrated power circuit MC33153 [6] serves as an amplifier of drive signal. The circuit is powered by 15V auxiliary supply and the upper transistors are powered by a galvanic isolated supply.

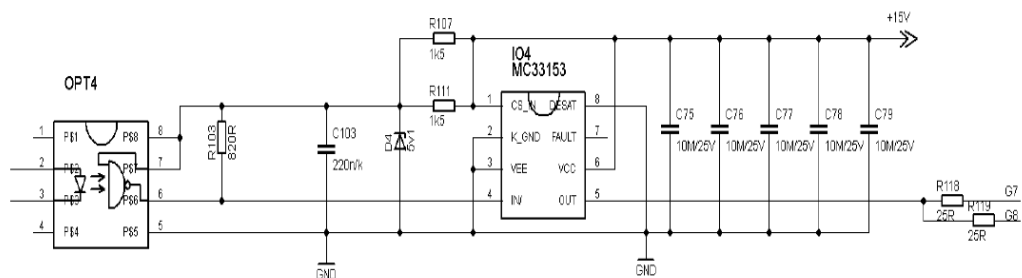

Figure 4 Diagram of the exciter used for power transistor [1]

3.4. SUPPLY

Auxiliary supply is produced from battery voltage by a help of power integrated circuit MC34063 [7] which serves as a step-down converter. The voltages 15V and 5V are produced this way. The voltage 3.3V which is necessary for DSC is produced by a voltage regulator.

The upper power transistors of the converter have to be powered by a galvanic isolated supply. The single acting permeable inverter with pulse transformer without output choke with switching frequency is 374 kHz is implemented for this purpose. Output voltage is 15V. Two parallel secondary windings are needed - one for each branch of the converter. This high frequency is characteristic for this circuit diagram because the demagnetization of the transformer is based on the parallel resonant circuit between primary winding inductance and capacitors. More detailed description of the converter is described in [1] and [8].

4. CONTROL STRUCTURE

As mentioned above, the motor is controlled by a help of a subordinate current control loop. The rider defines the requested current by throttle, and the control structure sets required current of the motor. Because the DC motor is used, positive correlation between current and torque of motor is paid ($I \sim T$). Then it can be spoken about torque control. This kind of control is really useful for traction vehicles. The block diagram of drive with control structure is shown in fig. 5. Control happens in DSC. The program is synchronized with the PWM modulator and it is repeated with frequency 25kHz. Analog inputs of the program are throttle value, actual current, energy buffer voltage and motor voltage. Sensing energy buffer and motor voltage with the throttle value is fundamentally necessary to calculate the value of requested current.

Working point of the combustion engine is set by help of servo. Generator output power is calculated in DSC and by help of pre-defined states, which are based on the optimum performance characteristics of the engine, the servo is set.

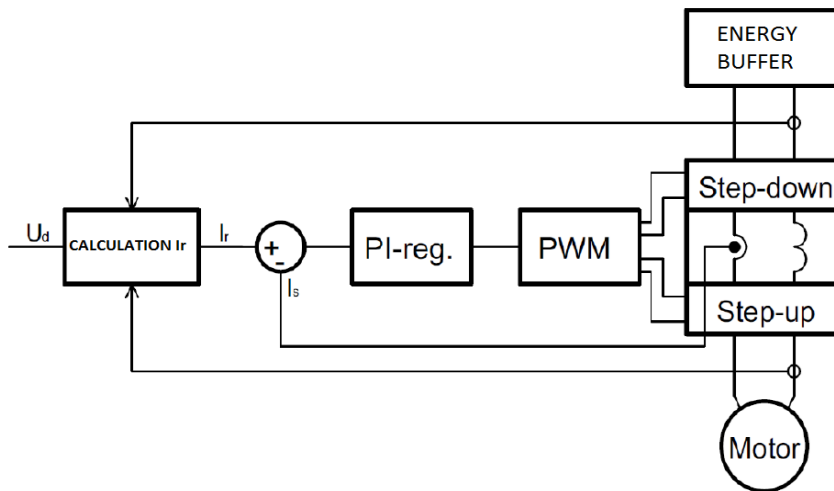

Figure 5 Control structure of the drive

5. CONVERTER CONSTRUCTION

Double-layer board is used in the converter. DSC is mounted at special four-layer board which was available. Layout of power stage is adapted to minimum size requirement as much as possible (see fig. 6). The final dimensions of the board are 167x130mm (including heatsink). The converter mechanical design allows using terminals to the motor and to the battery as a heatsink. That means that the heatsink is not isolated from transistor collector but is used as a conductor. Only parts of

heatsink with different potential are separated by insulating material. The most of current-carrying route is kept out of the PCB. The choke L1 is also connected to heatsink with potential of transistors T3, T4 and T7, T8. If this technology is not used then the route for high current will take a lot of space and size of PCB will be large.

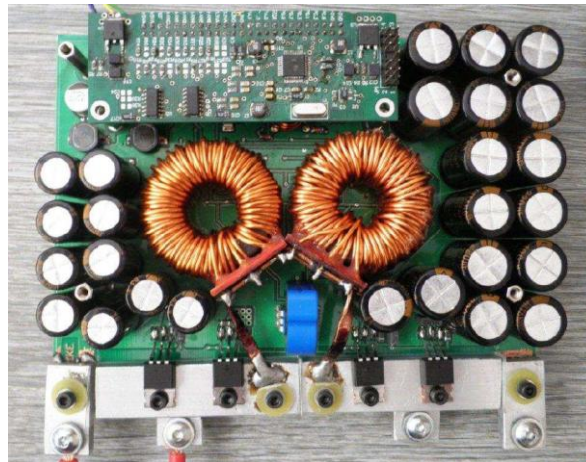

Figure 6 PCB of the traction DC/DC converter [2]

6. CONCLUSION

The design and construction of the DC/DC converter for hybrid bike was described in this article. The converter is a part of series-hybrid drivetrain. The converter is fully functional and the result of the measurement corresponds to the theoretical assumption. The average efficiency of the converter is 94% (theoretically up to 98%) and the average efficiency of the drive is about 84.5% which indicates good conditions for the use in electric traction. The maximal speed is 35km/h and the force of the drive is significant when compared with conventional electric bikes.

REFERENCES

- [1] PRUDÍK, M.; VOREL, P. Traction Converter for an Electric Bike. In LVEM 2011 Proceeding. Brno: Vysoké učení technické v Brně, 2011. s. 1-4. ISBN: 978-80-214-4362- 4.
- [2] Prudík, P. Trakční měnič pro motorové kolo se stejnosměrným motorem. Brno: FEKT VUT v Brně, 2011.65.
- [3] Freescale Inc.; *56F8300 Peripheral User Manual*, Rev. 10, 10/2007.
- [4] Datasheet.com [online], IRFB4110, MOS-FET semiconductor. Available from: <http://www.irf.com/product-info/datasheets/data/irfb4110pbf.pdf>
- [5] LEM.com [online], LEM CAS 50-HP, Current Transducer CAS series. Available from: http://www.lem.com/hq/en/component/option,com_catalog/task,displaymodel/id,90.E5.25.000.0/
- [6] AllDatasheet.com [online], MC33153, Single IGBT Gate Driver. Available from: <http://pdf1.alldatasheet.com/datasheet-pdf/view/12018/ONSEMI/MC33153.html>
- [7] AllDatasheet.com [online], MC34063, DC-to-DC Converter Control Circuits. Available from: <http://pdf1.alldatasheet.com/datasheet-pdf/view/12072/ONSEMI/MC34063.html>
- [8] Vorel, P.: Řídící členy v elektrických pohonech, Elektronické skriptum VUT Brno, UVEE FEKT VUT Brno, 2009.
- [9] Union of Concerned Scientists [online]. © 2010 [cit. 2012-03-05]. Available from: <http://www.hybridcenter.org/>