

PROPERTIES OF SHIELDING FABRICS

Zoltán Szabó

Doctoral Degree Programme (1), FEEC BUT

E-mail: szaboz@feec.vutbr.cz

Supervised by: Pavel Fiala

E-mail: fialap@feec.vutbr.cz

ABSTRACT

In connection with rapidly increasing progress in the radio communication services and other technical branches, which influence electromagnetic environment, the problems coupled with electromagnetic compatibility occur. Because of the electromagnetic interference minimization it is necessary to ensure the shielding of sensitive device, buildings, not least persons. The suitable alternative to the classical shielding materials can be special shielding-fabrics. The main advantages of this fabrics is the low weight, flexibility and its easy processability. The article deals with the measurement of some samples of fabrics, which are proposed for the electromagnetic shielding.

1. INTRODUCTION

Shielding is a very popular method of ensuring electromagnetic compatibility and of protecting electronic and electrical equipment and human beings against radiated electromagnetic energy. The knowledge of shielding effects of different types of material represents a basic prerequisite for further development and implementation of shielding devices. This paper presents an analysis of the measuring methods and a comparison of different materials in terms of their specific shielding effects. The absorption properties of the various submitted samples were measured using both a Crawford chamber and the Insertion loss method. In the samples, the capacity to absorb electromagnetic waves was determined with the help of a spectral analyzer.

2. MEASUREMENT METHODS

2.1. THE INSERTION LOSS METHOD

The insertion loss is evaluated as the loss (attenuation) of the emitted signal facilitated by the material under testing

$$A = U_0/U_1 \text{ expressed in dB, } A_{\text{dB}} = 20 \log (U_0/U_1),$$

where U_0 is the output voltage without the tested sample, U_1 is the same signal with the tested material.

The measured task (fig. 1) implemented with the help of a symmetrical line can be represented diagrammatically using an equivalent diagram with concentrated parameters. The equivalent diagram with concentrated parameters is shown in fig. 2.

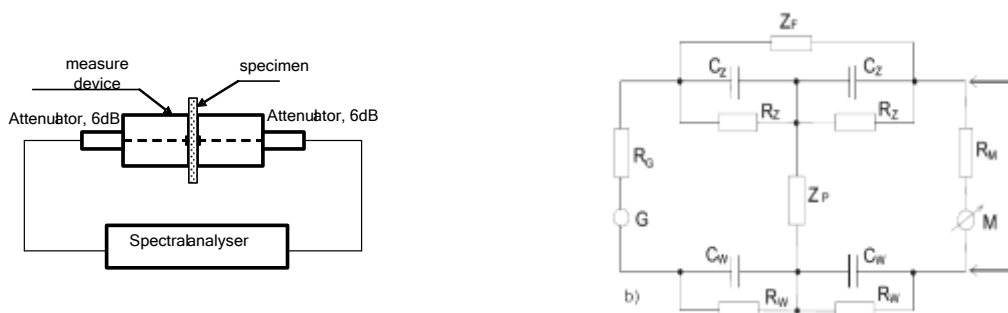

Figure 1: The device used for measuring the insertion loss

Figure 2: The equivalent model for loss measuring

The obtained results can be interpreted on the basis of this equivalent model of loss measuring. The parameters Z_F , C_Z , R_Z are eliminated during the task calibrating, and the insertion loss is represented by the Z_P element.

2.2. THE CRAWFORD CHAMBER

The measuring place set consisted of an Agilent spectral analyzer and a Crawford chamber. This chamber had been designed for measuring with a 50Ω line and for measuring samples with maximum dimensions of $80 \times 100 \times 30$ mm. For generating electromagnetic fields and analysing the resulting signal we used a spectral analyser produced by the Agilent company - the Agilent CSA Spectrum Analyzer N1996A-506 (from 100 kHz to 6 GHz). The apparatus incorporates both the signal generator and the spectrum analyzer.

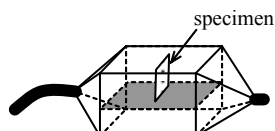

Figure 3: The position of the samples in the Crawford chamber

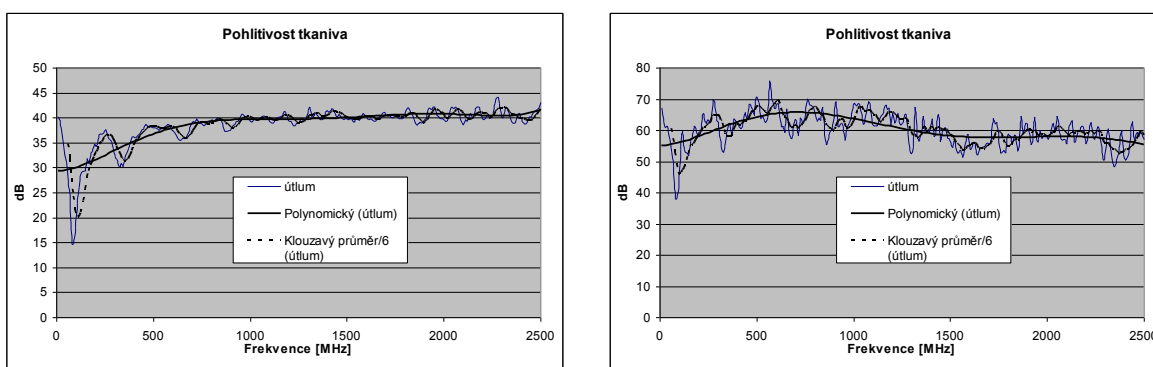

Figure 4: The loss in sample 1. A nonwoven fabric almost purely consisting of carbon filaments.

Figure 5: The loss in sample 2. A woven, high-quality nylon fabric

3. EXPERIMENTAL RESULTS

3.1. THE INSERTION LOSS METHOD MEASUREMENT

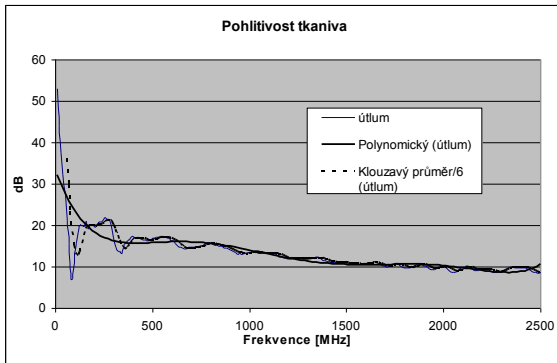

Figure 6: The loss in sample 3. A woven fabric, conductive components on the inside and pure cotton on the outside.

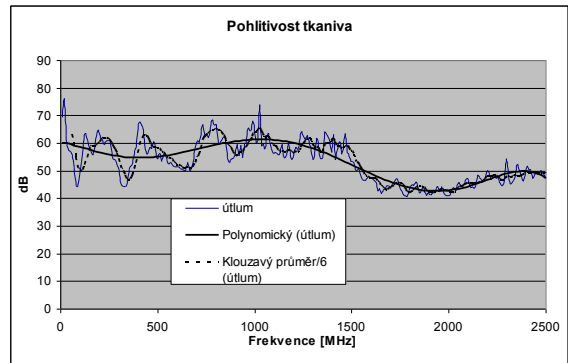

Figure 7: The loss in sample 4. A woven fabric, nylon fibre coated with tin and copper.

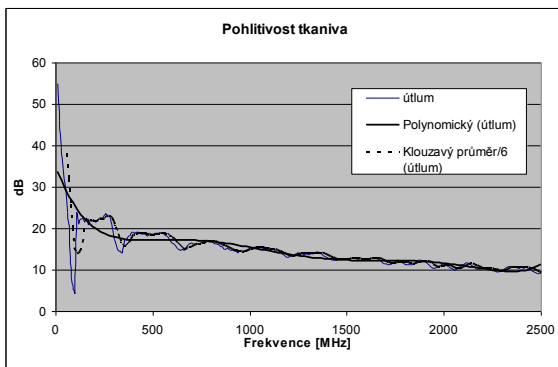

Figure 8: The loss in sample 5. A woven, polyester fibre fabric.

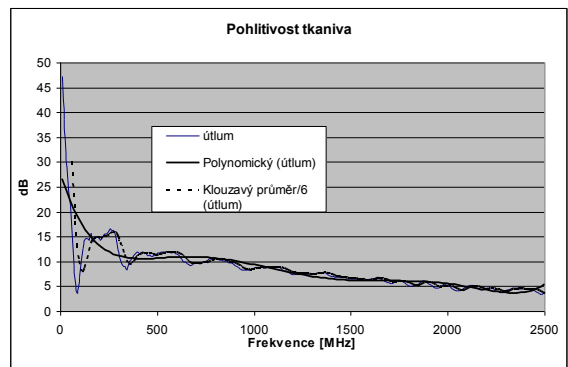

Figure 9: The loss in sample 6. A woven fabric, polyester fibre coated with copper and nickel.

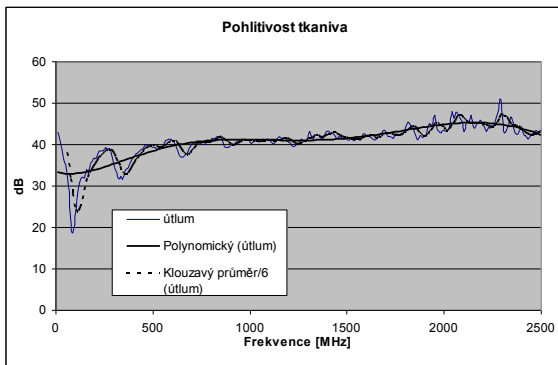

Figure 10: The loss in sample 7. FlecTron, resistivity $<0.09 \text{ ohm/m}^2$

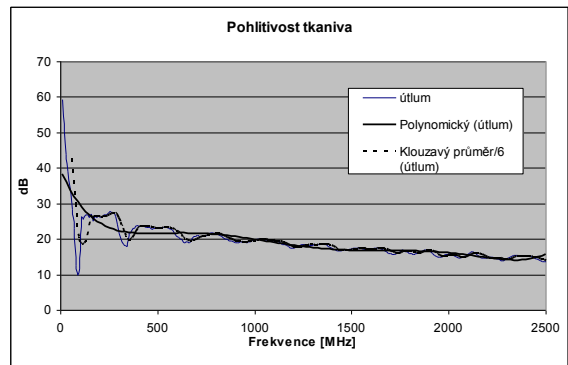

Figure 11: The loss in sample 8. FlecTron polyester, resistivity $<0.1 \text{ ohm/m}^2$.

3.2. THE CRAWFORD CHAMBER MEASURING

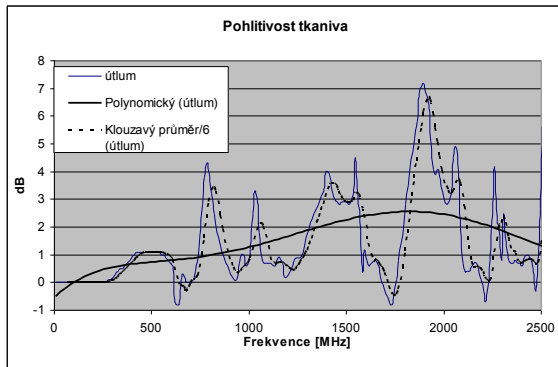

Figure 12: The loss in sample 1. Nonwoven fabric almost purely consisting of carbon filaments.

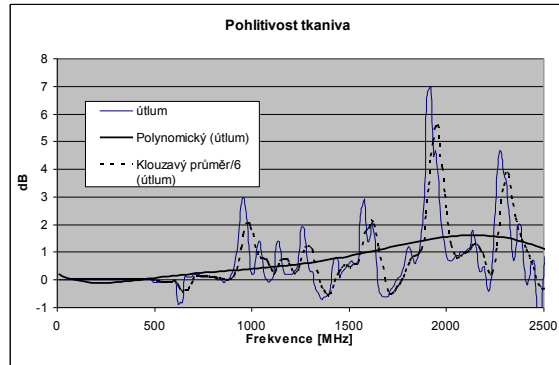

Figure 13: The loss in sample 2. A woven, high-quality nylon fabric.

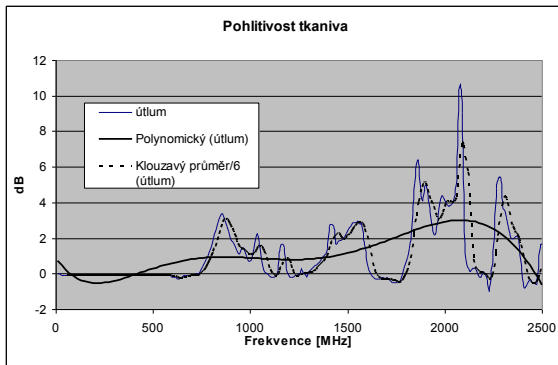

Figure 14: The loss in sample 3. A woven fabric, conductive components on the inside and pure cotton on the outside.

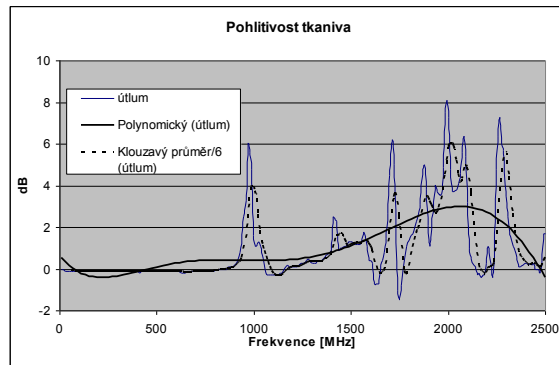

Figure 15: The loss in sample 4. A woven fabric, nylon fibre coated with tin and copper

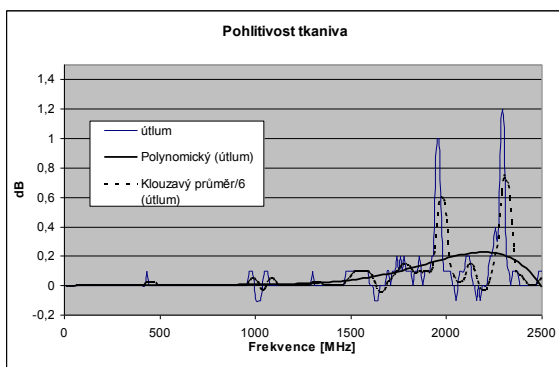

Figure 16: The loss in sample 5. A woven fabric, polyester fibre.

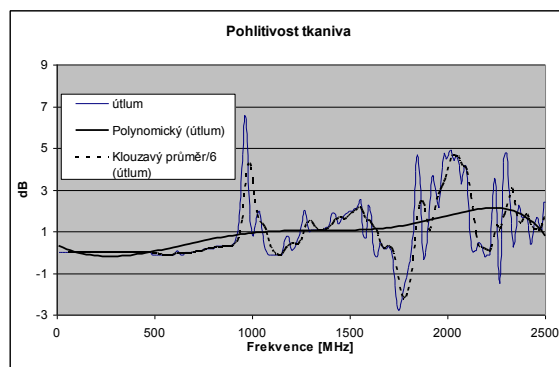

Figure 17: The loss in sample 6. A woven fabric, polyester fibre coated with copper and nickel..

On some frequencies in the diagrams there is present a marked, sharp decrease in loss to below 0 dB. This means that, instead of absorption, there have occurred reflections of the

electromagnetic waves due to an obstruction.

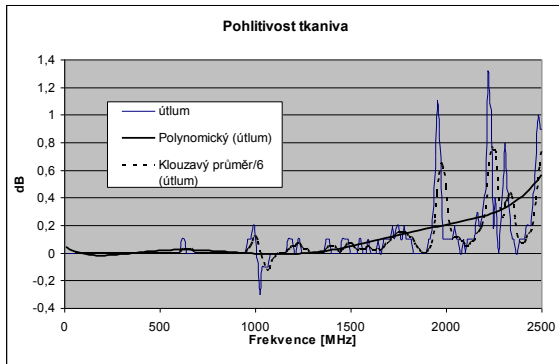

Figure 18: The loss in sample 7. FlecTron, resistivity $<0.09 \text{ ohm/ m}^2$

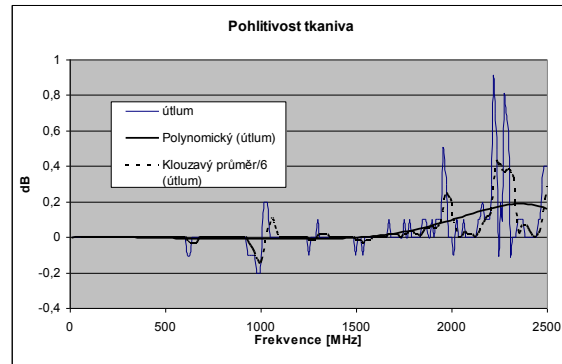

Figure 19: The loss in sample 8. FlecTron polyester, resistivity $<0.1 \text{ ohm/ m}^2$

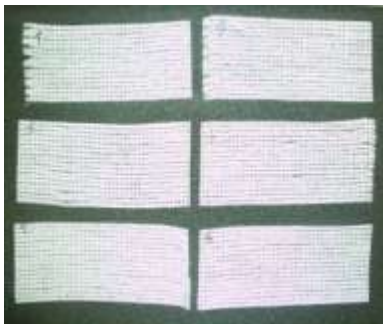

Figure 20: Samples 1 to 6



Figure 21: Samples 7 and 8 by FlecTron

4. CONCLUSION

The comparison of various types of material based on data provided by the manufacturer may prove misleading, especially in view of the different measuring methods applied. The paper presents a comparison of various materials realized by measuring the items under identical conditions but, importantly, applying different measuring methods. Even though the tabulation of the measured samples shows fundamentally different values, by comparing these values there may be defined the relation between a fabric structure and its shielding and absorption properties in the electromagnetic field.

ACKNOWLEDGMENTS

The research described in the paper was financially supported by research plans GA102/07/0389 and MSM0021630513.

REFERENCES

- [1] Agilent CSA Measurement Guide and Programming Examples, USA 2006.
- [2] J. Koprowska, M. Pietranik, W. Stawski, New Type of Textiles with Shielding Properties, FIBRES & TEXTILES in Eastern Europe, July/October 2004