

INITIAL ROTOR POSITION ESTIMATION FOR PERMANENT MAGNET SYNCHRONOUS MOTOR

Libor Veselý

Doctoral Degree Programme (1), FEEC BUT,
E-mail: vesely.libor@phd.feec.vutbr.cz

Supervised by: Pavel Václavek

E-mail: vaclavek@feec.vutbr.cz

ABSTRACT

This paper presents a method for initial rotor position estimation of permanent magnet synchronous motor. The method is based on current measurements, which turns by the inductance change with the level of the current flowing through the phase windings. An inductance change is proportional to the rotor position, which is measured by using high frequency signal injection. The effect of inductance saturation is used to estimate the polarity of the rotor magnet.

1. INTRODUCTION

Permanent magnet synchronous motors (PMSMs) have been used in many industrial applications because they have several inherent advantages e.g. rugged construction, easy maintenance, high power factor, high efficiency and suitability for wide speed ranges of constant power operation. High performance can be obtained by using vector control. The critical aspect to modern drive application is reliability. However, vector control requires information of rotor position. Traditionally speed and position sensing was obtained using incremental encoder, resolver and Hall effect detectors. These sensors add cost, weight, and degrade reliability. If the rotor position can't be exactly estimated, the starting torque of the motor decreases, and the large reversal rotation may be temporarily observed at start up. The first step to successful sensorless control is estimation of initial rotor position. This problem is solved by using pulse, which sets the rotor to defined position. However this applied solution is not possible in many practical applications.

Mathematical model of PMSM

The mathematical model of PMSM is derived from schematic representation of stator and rotor windings. The three-phase windings are representation by phase a, b, c.

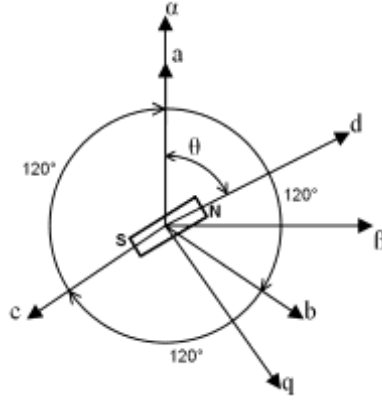

Figure 1: Model of PMSM

Figure 1 shows the model of the PMSM. The d-q frame shows the synchronously rotating reference frame where the d axis coincides with the north pole of the rotor. The orthogonal two-phase α - β frame is fixed to the stator windings and θ represents the actual angle of the rotor position.

Clarke transformation is used for transforming values (current, voltage, flux) from the three-phase stationary coordination system to α - β stationary orthogonal coordination system.

$$\begin{bmatrix} u_\alpha \\ u_\beta \\ u_0 \end{bmatrix} = \frac{2}{3} \begin{bmatrix} 1 & -1/2 & -1/2 \\ 0 & -\sqrt{3}/2 & \sqrt{3}/2 \\ 1/2 & 1/2 & 1/2 \end{bmatrix} \begin{bmatrix} u_a \\ u_b \\ u_c \end{bmatrix}$$

The d, q variables are obtained from a, b, c variables through the Park transform defined below:

$$\begin{bmatrix} u_q \\ u_d \\ u_0 \end{bmatrix} = \frac{2}{3} \begin{bmatrix} \cos\theta & \cos\theta - 2\pi/3 & \cos\theta + 2\pi/3 \\ \sin\theta & \sin\theta - 2\pi/3 & \sin\theta + 2\pi/3 \\ 1/2 & 1/2 & 1/2 \end{bmatrix} \begin{bmatrix} u_a \\ u_b \\ u_c \end{bmatrix}$$

The mathematical model is used for testing an initial rotor position estimation algorithm. A non-saturating model of PMSM doesn't information about polarity of the rotor magnet because the position estimation based on this model is locally stable at both poles. The following mathematical model of PMSM neglects saturation. However saturation is taken into account by parameter changes.

The following assumptions are made in the derivation:

- Saturation is neglected
- The induced EMF is sinusoidal
- Eddy currents and hysteresis losses are negligible
- There is no cage on the rotor

The two axis form of the equations (1) and (2) can be obtained with these assumptions above,

$$u_d = R i_d + \frac{d\Psi_d}{dt} - \omega \Psi_q \quad (1)$$

$$u_q = R i_q + \frac{d\Psi_q}{dt} + \omega \Psi_d \quad (2)$$

where

$$\Psi_d = L_q i_q \quad (3)$$

$$\Psi_q = L_d i_d + \Psi_f \quad (4)$$

and

$$L_q = \frac{3}{2} (L_a - L_b) \quad (5)$$

$$L_d = \frac{3}{2} (L_a + L_b) \quad (6)$$

u_d, u_q are the d, q axis voltages, i_d, i_q are the d, q axis stator currents, L_d, L_q are the d, q axis inductances, Ψ_d, Ψ_q are the d, q axis stator flux linkages, R is stator resistance and ω is synchronous frequency. These equations directly follow from the equations of the smooth-air-gap synchronous machine expressed in the rotor reference frame, but instead of the flux linkage produced by field winding, now the magnetic flux Ψ_f is present.

The electric torque is

$$M_e = \frac{3}{2} p_p \frac{(\Psi_f i_q + (L_d - L_q) i_d i_q)}{2} \quad (7)$$

p_p is the number of pole pairs.

And the equation for the motor dynamics is

$$M_e = M_L + B \omega + J \frac{d\omega}{dt} \quad (8)$$

M_L is the load torque, B is the damping coefficient and J is the moment of inertia and ω is the rotor speed.

The invert frequency is related to the rotor speed as follows

$$\omega = \frac{\omega_r}{p_p} \quad (9)$$

2. EXPERIMENTAL RESULTS

The experimental system for laboratory measurements is demonstrated in Figure 2.

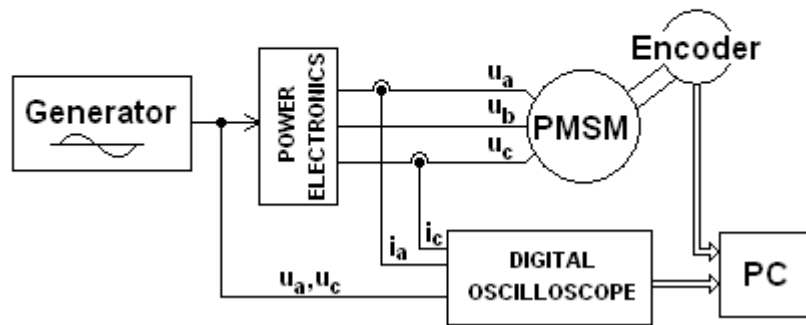

Figure 2: Configuration of experimental system

High frequency injection (500 – 900Hz) enters into power electronics and then to the stator windings. Shape of the current measurement by digital oscilloscope is plot in Figure 3. Figure 3 shows that it is possible to determine the actual electrical angle, but it is impossible detect a north or a south rotor pole. This problem is eliminated by applying a DC current to the stator winding. Figure 4 is a plot of the variation of stator current with DC current. When a north pole is aligned with the stator windings (for example phase a) the stator saturation is increased (stator flux and the flux produced by rotor magnet have the same direction) which slightly decreases the stator inductance, therefore increases current. When a south pole is aligned with the stator windings then the stator saturation is decreased (stator flux and the flux produced by rotor magnet have the inverse direction) which slightly increases the stator inductance, therefore decreases current. This effect can be used to estimate the position of a north or a south rotor pole.

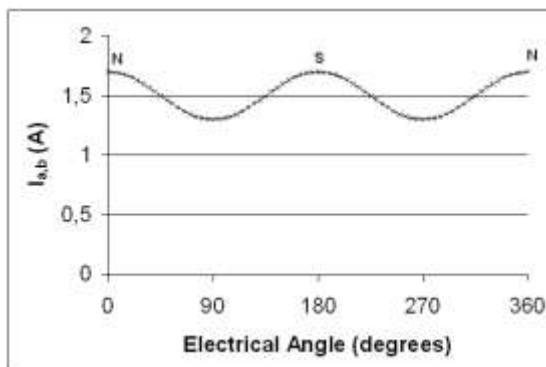

Figure 3: Stator current as a function of electrical angle

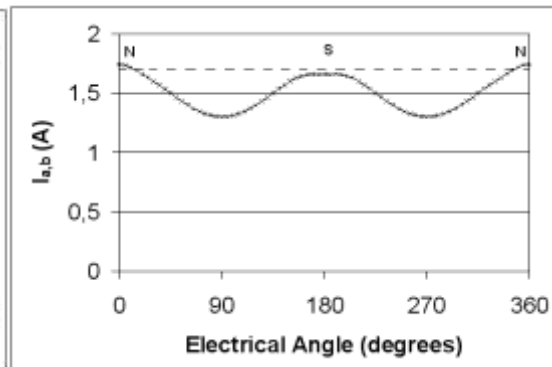

Figure 4: Stator current + DC current as a function of electrical angle

3. CONCLUSIONS

This paper has introduced a technique using injection of high frequency carrier with DC offset for initial rotor position estimation of PMSM. Experimental measurements have shown that increases or decreases of stator current amplitude are relatively small comparing with the noise. If saturation effect isn't considerable that it can be difficult to estimate the north or the south magnet pole of the rotor. DC stator current can change the initial rotor position in case of zero load torque.

ACKNOWLEDGEMENTS

The research has been supported by Czech Science Foundation under the project GA 102/06/0949 "Intelligent Control of Induction Machine and Synchronous Machine Electrical Drives", the Ministry of Education of the Czech Republic under the project 1M0567 "Centre for Applied Cybernetics"

REFERENCES

- [1] Caha, Z.: Elektrické pohony, Praha, SNTL 1990, ISBN 80-03-00418-7
- [2] Bowen, C., Jihua, Z., Zhang, R.: Modeling and Simulation of Permanent Magnet Synchronous Motor Drives, Northwestern Polytechnical University, pp. 905-908
- [3] Neony, Y., Lorenz, R.D., Jahns, T.M., Sul, S.: Initial Rotor Position Estimation of an Interior Permanent Magnet Synchronous Machine Using Carrier-Frequency Injection Methods, 0-7803-7817-2, 2003, pp.1218-1223
- [4] Schmidt, P.B., Gasperi, M.L., Ray, G., Wijenayake, A.H.: Initial Rotor Angle Detection of a Non-Salient Pole Permanent Magnet Synchronous Machine, Rockwell Automation Advanced Technology Labs, 1997